

## Realization of Full-mesh Wavelength Paths over Interconnected Star-shaped Wavelength Routing Networks

We propose a novel technique for interconnecting arrayed-waveguide grating (AWG) based star-shaped wavelength routing networks. This technique enables us to establish full-mesh wavelength paths between arbitrary nodes in two networks, which is difficult to realize without using our proposed technique.

We have already developed a wavelength routing network called “AWG-STAR” for large-capacity local networks. With this system, full-mesh wavelength paths between communication nodes can be assigned over a physical star topology network via a central AWG wavelength router. However, there had been no report on interconnecting multiple AWG-STARs, and we had to employ electrical routers to connect them, thus sacrificing the benefits of optical routers, namely low latency and low power consumption.

To deal with this issue, we propose a technique for connecting two AWG-STARs optically with a pair of single-mode fibers as shown in Fig. 1(a), and for assigning wavelength paths between any combinations of nodes that belong to different AWG-STARs as shown in Fig. 1(b).

With the proposed technique, cyclic AWGs with coprime repetition channel numbers ( $U_A$  and  $U_B$ ) are

employed as the wavelength routers, and each node transmits wavelength division multiplexed (WDM) signals with  $U_A \times U_B$  wavelengths. Figure 2 shows the proposed wavelength routing functions when  $U_A=6$  and  $U_B=7$ , and the forty-two wavelength signals are transmitted from node A1. At the 6x6 AWG router, seven signals with six channel intervals appear at each output port, and each of the nodes A1 to A5 receives a set of seven signals. The remaining seven signals are launched into a 7x7 AWG router and distributed to the nodes in AWG-STAR B. In the same manner, the forty-two wavelength signals transmitted from the other nodes can reach all the nodes in the network, and we can obtain full-mesh wavelength paths. We confirmed the proposed operating principle experimentally with a 10-Gbit/s prototype system.

This technique enables us to extend AWG-STAR networks by employing simple connections.

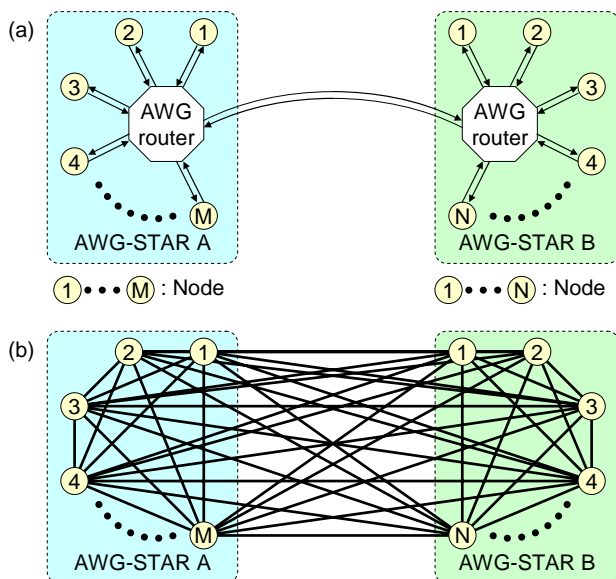

Fig.1 Network configuration (a) Physical topology (b) Wavelength path assignments

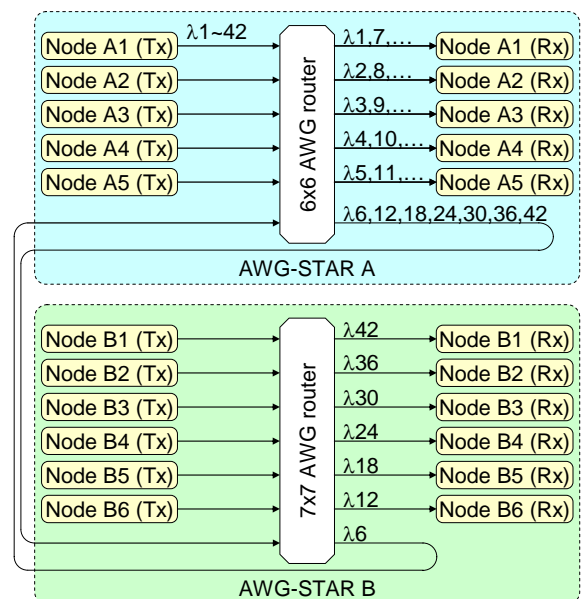

Fig.2 Wavelength routing functions when 6x6 and 7x7 AWGs are employed